



Procurement Strategy 2008 – 2010

Sal Khan
Head of Organisational Development & Customer Care
East Staffordshire Borough Council
Town Hall
Burton upon Trent
DE14 2EB

Table of Contents:

Section 1 – Purpose & Vision	3
Section 2 - Current Status	5
Section 3 - Partnership Working	6
Section 4 - Moving Forward.....	7
Section 5 – Strategy Life Cycle	20
Section 6 – Strategy Governance.....	21
Section 7 - Key Outcomes and Benefits	23
Section 8 - Risk Analysis - Risk Profile & Risk Assessment.....	25

Section 1 – Purpose & Vision

East Staffordshire Borough Council has a responsibility to manage the interface between itself and its supply base. The relationship is dynamic and constantly changing and so it is imperative for us to have a strategy in place that manages this relationship, aggressively seeking savings, providing efficiencies and value for money, and ultimately enabling the Council to deliver excellent customer-centric services in the most cost-effective way. The Council is embarking on a journey of continuous improvement and change, where it is constantly seeking and adopting innovative ways of working across the whole of the organisation.

The role of procurement in the Council is very much a joint corporate effort. The responsibility at Officer level for procurement lies with the Head of Organisational Development and Customer Care (reporting into the Director for Corporate Services) with member responsibility sitting with the Deputy Leader (Corporate Services). As budgets for all expenditure are devolved down to service level it is the responsibility of managers to manage these budgets and procurements effectively. The success of the procurement function requires the continued support of all Heads of Service and the Corporate Management Team.

This strategy is aimed at promoting effective procurement across the whole organisation. It strikes a balance between setting out a detailed plan for reforming procurement, with specific targets and a flexible planning framework. The Council needs to be flexible to be able to respond to the rapidly changing environment around public sector procurement and to learn from our own experience and the experiences of others. The rapidly changing environment is well illustrated by the pace of technological change currently associated with e-procurement.

The Council's vision is determined in the corporate plan as

“To concentrate on local services, continue to make the Council cost effective and to increase partnership working with other public agencies to improve our local way of life.”

The mission is to achieve this by being open and transparent with a “can do culture”, which involves communications across Burton, Uttoxeter and our rural areas. This naturally effects businesses as well as members of the public.

The aims of this strategy are to:

- To make sure that procurement planning reflects our Corporate vision, our values, aims and outcomes;
- To secure commitment to effective and efficient procurement from Members and officers at all levels throughout the organisation;
- To provide a focus for procurement, helping us to co-ordinate procurement and use resources as effectively as possible;
- To plan the way forward on reforming, and continuously improving, our procurement functions;
- To help us to plan budgets, tasks and targets to meet the main procurement aims identified;
- To draw together the various issues currently facing public sector procurement and produce a strategy that will help us to respond positively to the Government's agenda;

- To encourage long-term thinking and commitment to strategic procurement issues; and
- To identify and promote the benefits of strategic procurement.

The diagram below illustrates how the Procurement Strategy fits in with the wider Organisational Strategy and supporting business strategies to feed into the Council Vision. It also clearly shows its dependencies in order for it to be effective.

Diagram 1 - How Procurement fits into the Wider Organisational Strategy

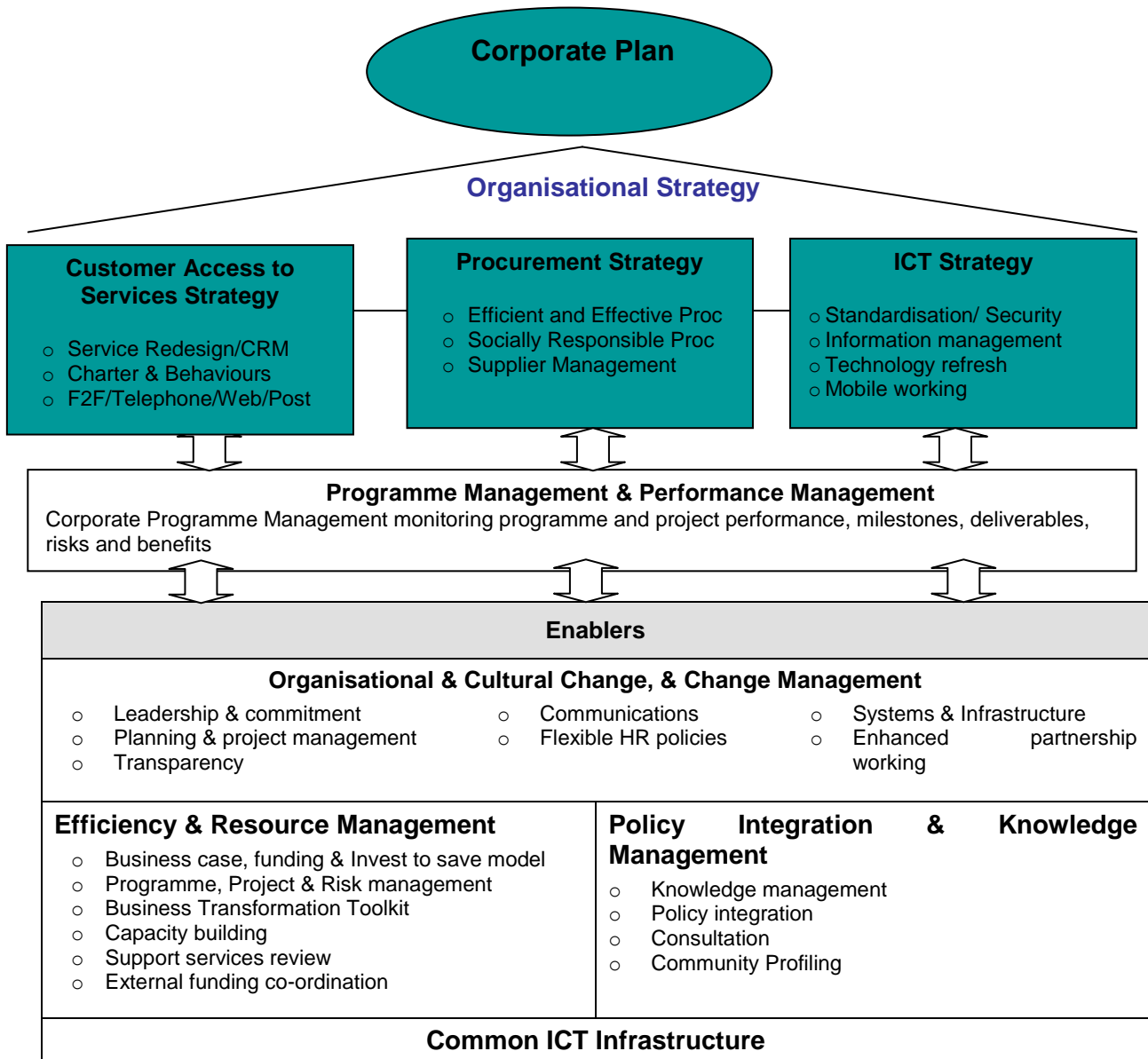

Section 2 - Current Status

The Council's approach to procurement has been to devolve the function to service level, with each individual budget holder being able to procure goods and services from whatever supplier they wished, as long as Contract Standing Orders were followed. The Council has not been able to place adequate controls on the processes to ensure that we are dealing with the right organisations in the first place and are also utilising the best approach to deliver procurement. There is no noticeable monitoring of suppliers on the Creditors system and there has been very limited progress with collaborative working or through the use of electronic procurements.

The previous strategy (2004-2007) and set-up of the procurement function was not effective and did not really deliver any significant benefits to the Council. Since May 2007 any continuation in procurement strategy along the previous route has ceased and a more aggressive approach, initially to savings, has been implemented by working closely with the experts in the organisation. This has provided savings of almost £180K (which is in excess of the Corporate Plan target of £150K) as of November 2007, all of which have been offered up into the Budget Setting process for 2008, benefiting the Council as a whole.

Approach to developing this Procurement Strategy

This Strategy has been developed over the course of Q3 2007/08, building on the Council's approved new Corporate Plan and ensuring that its wider agenda which includes, regeneration, community engagement, equalities, sustainability are included as well as addressing efficiencies and savings.

Recent developments have demonstrated that it is better for the Council to engage the relevant specialists in procurement decisions at the start and to this effect Heads of Service and Managers will be more involved with the decision making processes around procurement, but with the right amount of controls. In the context of this strategy, this is assumed to be ongoing.

Technology

Technology has not featured very much in the previous procurement strategy nor did it play a major role in the Council's previous approach. However, moving forward, technology is essential for the delivery of this strategy. There will be more reliance on ICT, in particular the new Financial Management System, which will improve the way that ordering is carried out and suppliers are managed and paid; E-Procurement will enable the Council to punch out to approved electronic catalogues and E-Tendering will reduce the amount of manual administrative tasks that are naturally associated with the tendering process.

Section 3 - Partnership Working

Partnership working where it makes sense plays a part in helping the Council to achieve its wider aspirations as detailed in the Corporate Plan. In the context of this strategy it is essential. Collaborative procurement is perhaps one of the most obvious benefits that can be derived from partnership working. This covers many areas from taking part in national consortium arrangements through Catalyst, to maximising the Council's impact through SOPO (Society of Procurement Officers) to joint procurement of goods and services at a local level.

The Council will work in a much more proactive manner with the West Midlands Centre of Excellence, ensuring that we pick up on and share good and best practice and continue to work on issues of mutual interest.

The emphasis on nurturing and maintaining partnerships will remain with the services initiating the procurement.

We also need to look into collaborations through other organisations where they make sense. These include:

- Staffordshire Purchasing offer a wide range of contracts and purchasing opportunities for Councils in Staffordshire
- We will look at opportunities for linking into existing contract arrangements with Staffordshire County Council
- We will look at smaller collaborations with neighbouring local authorities and local businesses to ensure that we are gaining the best possible deals
- Looking into services that can also be provided through the voluntary sector
- Joining up on national initiatives and market places that demonstrate best value and best practice

Section 4 - Moving Forward

Procurement is an important part of way we deliver public services. Buying and managing external resources is essential to providing best value services that are economic, effective and efficient.

Whilst we want to deliver best value, ensuring we are negotiating the best deals possible with our supplier base we must balance this against the need to ensure that our equalities agenda is taken into account and that we are also procuring ethically and also encouraging our local small and medium sized enterprises to do more business with the Council.

The Procurement Strategy is fundamental to the Council's bigger change agenda and the diagram below illustrates how we envisage moving forward.

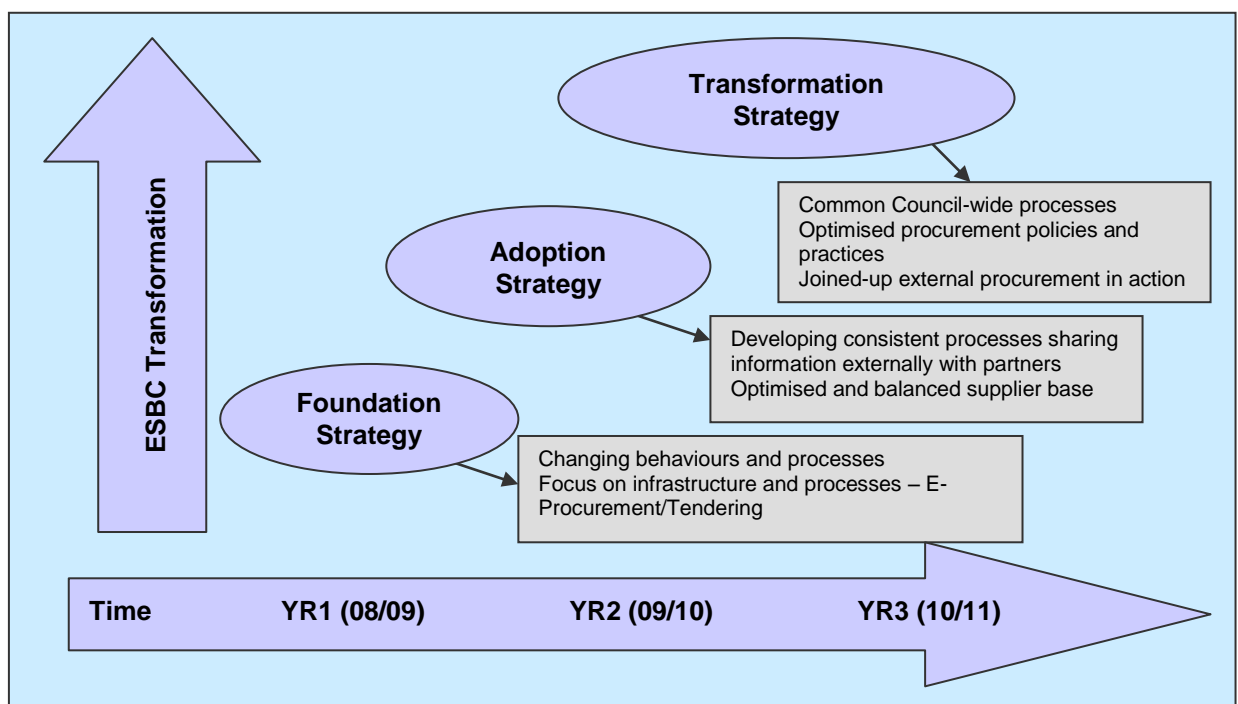

For the purposes of the Procurement Strategy we are aiming over Y1 and Y2 to reach the 'Adoption Strategy' phase. This builds on the Y1 foundation enabling us to move to a full transformation strategy with common council wide, optimised processes and practices that are derivatives from this Strategy. By the end of Y3, we are aiming for truly joined up external procurements with collaborations across the public sector.

The rest of this chapter details the main components within the strategy. These are categorised into the following areas:

Efficient and Effective Procurement:

Efficient and effective procurement is essential if we are to show that we are achieving value for money on goods and services. The areas that will be covered include Electronic Procurement, Efficiency and value for money, collaborative procurements, controls and standards and performance management. It is likely that changes to Contract Standing Orders will be required.

Socially Responsible Procurement:

Socially responsible procurement is covered by recognising and managing our activities which have an effect on the Borough and society at large. This section will focus on areas of sustainability, equalities in procurement, “thinking local” and the impact on the environment at large.

Supplier Management:

Supplier management recognises the fact that we need to encourage a mixed range of suppliers, (including best of breed, small and medium sized enterprises, ethnic minority businesses, social enterprises etc) we also need to ensuring that we have robust performance management frame work in place to ensure that we not only have the right “approved suppliers” on our books but that the suppliers are delivering and achieving their obligations to us, the customer.

ESBC – Procurement Strategy 1. Efficiency and value for money	Expected start: Nov 07	Expected end Dec 10	Component Lead: Head OD/CC
--	---	--------------------------------------	-----------------------------------

Brief Description:

We will use innovation and best practice, including the appropriate use of new technology and improved, simplified business processes to achieve quality and efficiency benefits. We will utilise the functionality contained within the new financial management system to deliver electronic, paperless and cheque-less procure-to-pay, thus releasing savings and efficiencies through less paper and less unnecessary handling of orders and invoices.

The Agresso Financial Management System (FMS) will provide a number of benefits as described in the business case for its implementation. One of the benefits from this is the ability to deliver electronic procure-pay facilities. A typical workflow of such a process is presented below:

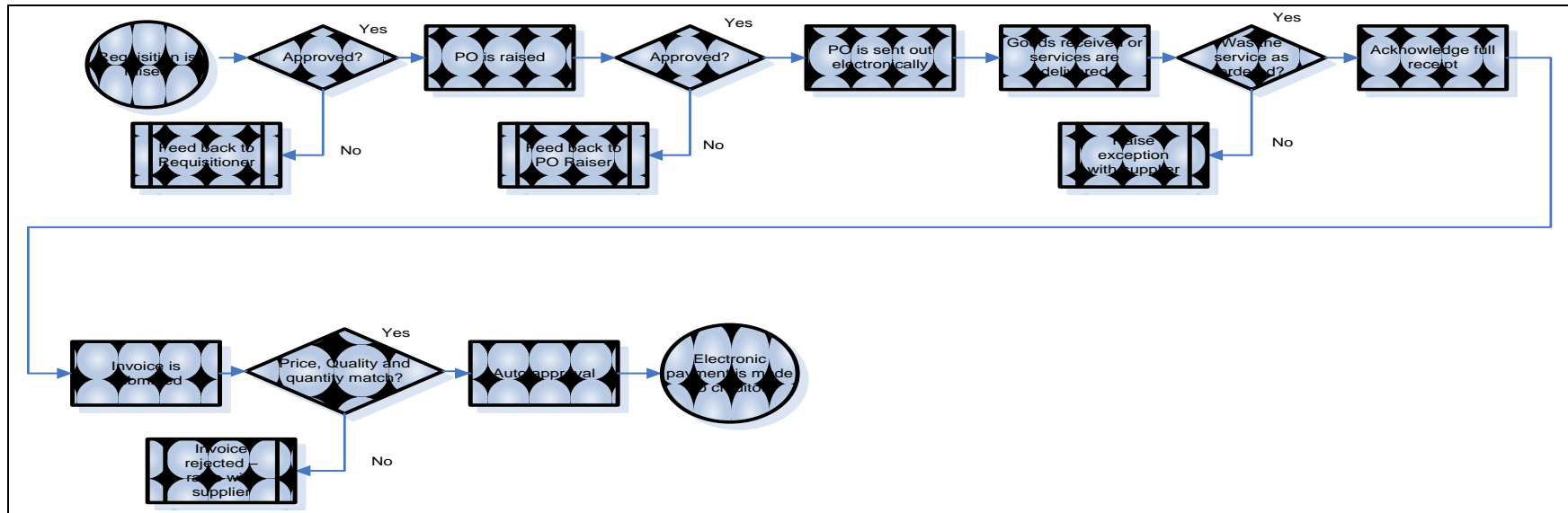

This will enable the officers to raise a requisition, get a purchase order raised, receive the goods (or services) and record this electronically on the FMS. When the invoice is received it is entered onto the FMS and if the goods, or services have been received, the purchase order details match up and there is no stop on the account then the invoice can be automatically matched to the other details and assuming all is in order then a payment can be made

ESBC – Procurement Strategy		Expected start:	Expected end	Component Lead: Head OD/CC
1. Efficiency and value for money		Nov 07	Dec 10	
<p>electronically to the supplier. This will be the starting point for improved processes around the procurement function – we will not only be saving on paper but also on envelopes, postage, and associated handling of purchase orders, invoices and cheques.</p> <p>We will continue to increase value for money and build on the savings identified in Year 1 of the Corporate Plan and further develop the Sustainable Savings Register (as presented to Cabinet in December 07) and also continue to focus our requirements on quality and price rather than price alone. We will utilise best practice mechanisms such as Catalyst and</p>				
Key Milestones and timescales	Key Outcomes & Benefits:			Key Performance Measures:
<p>Efficiency & VFM Component:</p> <ul style="list-style-type: none"> • Initiation: • Baseline activities • Review processes • Implement new process • Training requirements • Implement savings 	<p><i>Improving Council efficiency and value for money through best practice, modern ICT, innovation and improved business processes delivered by responsive, well informed and trained officers</i></p> <ul style="list-style-type: none"> • Challenge to purchases will be dealt with at source • Budget managers will be able to approve purchases electronically and see how these purchases are reflected in their budgets • There will be improved monitoring and review mechanisms with better management controls and real-time reporting facilities • Improved efficiencies and savings for the Council through better processes • Improved procurement through the continued aggressive approach to savings. • Effective monitoring and review mechanisms, including customer feedback, for all customer service operations. • Improve the quality and consistency of procurement and budget management across the council • Improved staff confidence and morale 			<ul style="list-style-type: none"> • Reduction in paper transactions • Increased savings • Improved control on budgets • Reduction in process time and cost in the procure-pay cycle • Improvement in BVPI 8
Component Dependencies	<ul style="list-style-type: none"> • New Financial Management System • E-Procurement and E-Tendering. • Continued support of Heads of Service • Training programme 			

ESBC – Procurement Strategy		Expected start:	Expected end	Component Lead: Head OD/CC
2. E-Procurement and E-Tendering		Feb 08	Dec 10	
Brief Description:				
<p>Electronic Procurement is more than just electronic ordering – it is essentially “doing business” electronically. If done correctly e-procurement can improve and streamline the procurement process, improve communication and provide cost savings.</p> <p>We will utilise electronic procurement in a number of different ways. Firstly the electronic communication will be improved and all necessary information, including a “How do I?” section will be provided on the Intranet for officers (who want to know how to carry out procurement) and on the website for businesses (who want to know how to do business with the Council). Electronic catalogues will be employed, enabling the offices to source previously approved goods and services at agreed process from approved suppliers – this will allow product controls to be imposed – fir example if the Council decided that it would only utilise two different sizes of envelope in order to ensure optimum postal charges, then an electronic catalogue can be set up that only allows those products to be purchased. We will also assess various electronic market places, such as the IDEA Market Place, and also assess the viability of procurement cards for the Council.</p> <p>Electronic tendering will be introduced on goods and services where it makes sense. We will be linking into the West Midlands Centre of Excellence product, Bravo, a fully secure, e-sourcing portal providing a full service from OJEU notice submission through to award of contract. In the future we will also evaluate the effectiveness of Electronic Auctions.</p> <p>We will use innovation and best practice, including the appropriate use of new technology and improved, simplified business processes to achieve quality and efficiency benefits. We will utilise the functionality contained within the new financial management system to deliver electronic, paperless and cheque-less procure-to-pay, thus releasing savings and efficiencies through less paper and less unnecessary handling of orders and invoices.</p>				
Key Milestones and timescales	Key Outcomes & Benefits:			Key Performance Measures:
E-Procurement Component: <ul style="list-style-type: none"> • Initiation: • Baseline activities • Review processes • Implement new process 	<i>Utilise technology to improve efficiency and effectiveness by reducing the cost of the procurement process for the Council and its suppliers and encouraging officers and suppliers to adopt e-procurement and e-tendering methods</i> <ul style="list-style-type: none"> • Electronic catalogues will be employed with products seamlessly linked into the FMS. • External electronic market places will be assessed and utilised, thereby increasing the 			<ul style="list-style-type: none"> • Reduction in paper transactions • Increased savings • Information available on-demand • Improved control on

ESBC – Procurement Strategy 2. E-Procurement and E-Tendering		Expected start: Feb 08	Expected end Dec 10	Component Lead: Head OD/CC
<ul style="list-style-type: none"> • Training requirements • Implement new systems 	<p>electronic catalogue base</p> <ul style="list-style-type: none"> • Web based information on both the intranet and Internet will improve communication • Electronic tendering products will make it easier for the Council to carry out tendering and improve the management and assessment of tenders • Improved staff confidence and morale • Reduce the number of queries on procurement that are transferred to officers • Electronic Market places will generate economies of scale in procurement opportunities and provide the ability to join up and proactively source goods and services with partners • Free up resources for professionals to concentrate on more complex technical service delivery 			<p>what is procured</p> <ul style="list-style-type: none"> • Reduction in process time and cost in the procure-pay cycle
Component Dependencies	<ul style="list-style-type: none"> • New Financial Management System • E-Procurement and E-Tendering. • Robust ICT including Web based tools • Training programme 			

ESBC – Procurement Strategy		Expected start:	Expected end	Component Lead: Head OD/CC
3. Performance Management and Controls		Nov 07	Dec 10	
Brief Description:				
<p>Performance Standards and monitoring are important methods of assuring quality is delivered also ensuring we continue to improve the way we deliver services. We will work with the West Midlands Centre of Excellence to develop a set of key indicators and will use performance management analytics (from the Financial Management System and other Purchasing Tools) to monitor and improve our procurement systems. These will also include the following:</p> <p style="padding-left: 40px;">Reporting to BVPI and Corporate Plan Targets, Setting up a Savings Register, Stakeholder Satisfaction Surveys, Procurement Strategy Targets; Annual Service Planning Targets</p> <p>Whilst we endeavour to make our procurement processes as efficient as possible there is the realisation that there are controls and restrictions that relate specifically to public sector procurement. We have a duty to our citizens and taxpayers to apply controls and consistent standards across the Council to provide value for money. The main controls in place are:</p> <p style="padding-left: 40px;">EU Directives and national regulations, Contract Standing Orders, our Procurement Strategy, National Procurement Strategy for Local Government, Guidance Documents, Internal and External Audit functions</p> <p>Whilst we need to make sure that we keep up to date with any relevant changes, we also need to ensure that our internal controls and standards offer a flexible approach to procurement and do not hinder progress with this strategy.</p>				
Key Milestones and timescales	Key Outcomes & Benefits:			Key Performance Measures:
<p>Performance Component:</p> <ul style="list-style-type: none"> • Initiation: • Baseline activities • Review processes • Implement new process • Training requirements • Implement new systems 	<p><i>Promoting Performance Management and making sure that suitable controls are in place to maintain standards and reduce risk</i></p> <ul style="list-style-type: none"> • We will agree performance standards and develop methods for measuring against these. • We will improve the range and quality of financial and general procurement management information available • We will analyse spending on corporate framework agreements 			<ul style="list-style-type: none"> • Performance targets in place and adhered to • Corporate standard documents in place • Controls and standards are streamlined

ESBC – Procurement Strategy 3. Performance Management and Controls		Expected start: Nov 07	Expected end Dec 10	Component Lead: Head OD/CC
	<ul style="list-style-type: none"> • We will review progress against this strategy • We will work with services to make sure that controls and standards are streamlined, we will secure value for money and never suppress new ideas • We will make sure there is better co-ordination of skills across the Council by implementing corporate standard documents 			
Component Dependencies	<ul style="list-style-type: none"> • New Financial Management System • E-Procurement and E-Tendering. • Agreed PIs and Controls 			

ESBC – Procurement Strategy		Expected start:	Expected end	Component Lead: Head OD/CC
4. Equalities and Ethical Procurement		Nov 07	Dec 10	
Brief Description:				
<p>This is a very important component which features in with the Council’s aims to ensure it practices and delivers on its Equalities agenda. We will use our influence to promote a positive approach to equality and diversity. We will give advice to our suppliers on equality and will ensure that any of our new awards to contractors promote equality and diversity and meet our targets as set out in the Council’s live Equalities Strategy and Equalities Action Plan.</p> <p>We will ensure that we establish mechanisms for ensuring that equality targets are delivered by contractors through contract management and that we have standard questions on equality on PQQs for tenders and also on the questionnaires needed to be completed in order to become an approved supplier for the Council. For agencies delivering services on behalf of the Council we will include within contracts a requirement to deliver an affective and appropriate service, fairly and without unlawful discrimination. We will carry out equal opportunities surveys to monitor the ongoing equalities developments of our supplier base and tenders and ensure they are following our required code of conduct.</p> <p>We will inform BME businesses, and others, about our changes and put in a mechanism that updates them on up coming tendering and contract opportunities. It is important to note however that whilst we may actively communicate with these groups we will not provide them with special treatment for achieving approved supplier status.</p> <p>Ethical procurement is more than just buying “fair-trade”. It concerns the living and working standards of people in the Borough, in the County, nationally and internationally which may be affected by our procurement activities. Not withstanding the issue that we need to work to best value we will introduce ethical considerations into our contracts and increase its awareness and importance of related issues with suppliers.</p>				
Key Milestones and timescales	Key Outcomes & Benefits:			Key Performance Measures:
Equalities/Ethical Component: <ul style="list-style-type: none"> • Initiation: • Baseline activities • Review processes • Implement new process • Training requirements 	<p><i>We will promote procurement practices which contribute to the Council’s priorities on equality and diversity by providing information on equality issues and making sure we treat all our suppliers equally</i></p> <ul style="list-style-type: none"> • Procurement will contribute to the Council’s overall equality agenda and will also contribute to the Council’s work towards obtaining Level 3 and Level 4 of the Equality Standard for Local Government. 			<ul style="list-style-type: none"> • Increase in awareness of ethical and equality issues with our suppliers • Increase in suppliers that are contributing to our equalities agenda

ESBC – Procurement Strategy 4. Equalities and Ethical Procurement		Expected start: Nov 07	Expected end Dec 10	Component Lead: Head OD/CC
<ul style="list-style-type: none"> • Implement new systems 	<ul style="list-style-type: none"> • We will raise the profile of ethical procurement which will have a positive impact on the community at large • We will ensure that our supplier base is delivering its services in an equitable and ethical manner 		<ul style="list-style-type: none"> • Increase in tender submissions from BME enterprises in the Borough • Improved reporting on the supplier base 	
Component Dependencies	<ul style="list-style-type: none"> • Assistance from Legal and Audit regarding changes necessary in Contract Standing Orders • FMS reporting attributes • Robust approach to Supplier Management • Training programme 			

ESBC – Procurement Strategy 5. Thinking Local Procurement		Expected start: Nov 07	Expected end Dec 10	Component Lead: Head OD/CC
Brief Description:				
<p>We need to look after the borough, and this done through a combination of ensuring that the economic sustainability of the Borough is maximised and also that the impact on the local environment (and also environment at large) is reduced.</p> <p>We will continue to work with local SMEs in the procurement process to support the Council’s local regeneration strategy. We will develop a database of local businesses that are capable of delivering goods and services to the Council (and ensuring they meet the approved supplier requirements) in order to ensure that they receive equitable opportunities in conducting business with the Council. This will be complemented with Web-based information that provides “Frequently Asked Questions” and “How do I?” sections to make it easier for them to understand what their requirements are.</p> <p>We will also place sustainable and environmental checks in place for contract renewals, which will link into an agreed “Top 10 Environmentally Sensitive Areas for Action List” and from a practical approach when we when we look at utilities as an example we are ensuring that any contracts contribute to the Council’s environmental standards and requirements.</p>				
Key Milestones and timescales	Key Outcomes & Benefits:			Key Performance Measures:
Equalities/Ethical Component: <ul style="list-style-type: none"> • Initiation: • Baseline activities • Review processes • Implement new process • Training requirements • Implement new systems 	<i>Reduce the negative effect on the environment and the Borough’s regeneration through the goods and services we buy and by encouraging a varied supply market.</i> <ul style="list-style-type: none"> • This contributes to the Council’s corporate priorities of a cleaner, safer, healthier and happy environment and also encourages and develops local prosperity • It will ensure that issues such as sustainability and thinking local are built into the Council’s procurement process • Systems will be developed that make it easier to buy local and sustainable products and services • If products have a cost associated with future disposals, these will be taken into account when going through any procurement or tendering exercise. • We will continue to develop plans to include small businesses • We will assess the viability of streamlining our processes specifically for SMEs. 			<ul style="list-style-type: none"> • Increase of awareness of sustainability and the environment with our supplier base • Increase in local businesses in our supplier base • Increase on the positive impact on the Council’s environmental agenda

ESBC – Procurement Strategy 5. Thinking Local Procurement	Expected start: Nov 07	Expected end Dec 10	Component Lead: Head OD/CC
Component Dependencies	<ul style="list-style-type: none">• Assistance from Legal and Audit regarding changes necessary in Contract Standing Orders• FMS reporting attributes• Robust approach to Supplier Management• Training programme		

ESBC – Procurement Strategy		Expected start:	Expected end	Component Lead: Head OD/CC
6. Approved and Performing Suppliers		Nov 07	Dec 10	
Brief Description:				
<p>Suppliers will be managed across the whole of the procurement lifecycle. In the first instance suppliers will need to demonstrate that they meet the Council’s requirements to become a supplier.</p> <p>These will include being able to conduct business electronically and offering competitive prices through to meeting the Council’s equalities and ethical requirements. Only organisations that meet these requirements will be allowed to be entered onto the Purchasing System and those that do not meet the requirements will not be allowed to conduct business with the Council.</p> <p>This will be the commencement of the monitoring and from here on suppliers will be monitored on an ongoing basis along the original requirements to ensure that the supplier is maintaining its original commitments and in addition to this there will also be the inclusion of performance management ensuring that the supplier is also performing (through analytics provided from the Financial Management System) to the required level as a provider of goods and services to the Council.</p>				
Key Milestones and timescales	Key Outcomes & Benefits:			Key Performance Measures:
Approved and Performing Suppliers Component: <ul style="list-style-type: none"> • Initiation: • Baseline activities • Review processes • Implement new process • Training requirements • Implement new systems 	<i>Introducing approval processes and performance management across all suppliers ensuring the Council is doing business with approved and performing organisations</i> <ul style="list-style-type: none"> • The Council is carrying out business with suitable organisations • The Council’s supplier base is performing to suitable • Poor performing organisations that continue to fail on deliveries and quality will be struck off the supplier register • Visibility on all suppliers will be available as key management information • Measures will be taken to ensure that equal opportunities are provided to local businesses and SMEs to allow them to be able to compete with the larger service providers 			<ul style="list-style-type: none"> • Increase of awareness of performance with our supplier base • Council’s creditors list only includes approved suppliers • Increase in performing suppliers • Reduction of suppliers and duplicates on the creditors list
Component Dependencies	<ul style="list-style-type: none"> • FMS reporting attributes • Head of Service contributions to approved supplier list and ongoing monitoring • Communication to service providers on expectations 			

Section 5 – Strategy Life Cycle

A High-level Gantt Chart is provided below which illustrates the Strategy Life Cycle.

Whilst it is acknowledged that there is limited detail in the time line this will be filled out accordingly as the components in Section 4 are worked up in more detail.

ID	Task Name	Duration	Start	Finish	2008				2009				2010			
					4Q07	1Q08	2Q08	3Q08	4Q08	1Q09	2Q09	3Q09	4Q09	1Q10	2Q10	3Q10
1	ESBC Access to Services Strategy	827 days	Thu 01/11/07	Fri 31/12/10												
2	Efficient and Effective procurement	827 days	Thu 01/11/07	Fri 31/12/10												
3	Efficiency and Value for Money	827 days	Thu 01/11/07	Fri 31/12/10												
4	E-Procurement and E-Tendering	761 days	Fri 01/02/08	Fri 31/12/10												
5	Performance Management and Controls	827 days	Thu 01/11/07	Fri 31/12/10												
6	Socially Responsible Procurement	784 days	Tue 01/01/08	Fri 31/12/10												
7	Equalities and Ethical Procurement	784 days	Tue 01/01/08	Fri 31/12/10												
8	Thinking Local Procurement	761 days	Fri 01/02/08	Fri 31/12/10												
9	Supplier Management	740 days	Mon 03/03/08	Fri 31/12/10												
10	Approved and Performing Suppliers	740 days	Mon 03/03/08	Fri 31/12/10												

Section 6 – Strategy Governance

As this is a very challenging programme of work ensuring that the right governance and controls are placed on it are of extreme importance. The suggestion is to utilise Prince2 and MSP (Managing Successful Programmes) to provide the relevant controls and management of the strategy and its underpinning programme of work with CMT effectively acting as the Corporate Programme Board for any area of work that constitutes a project initiation.

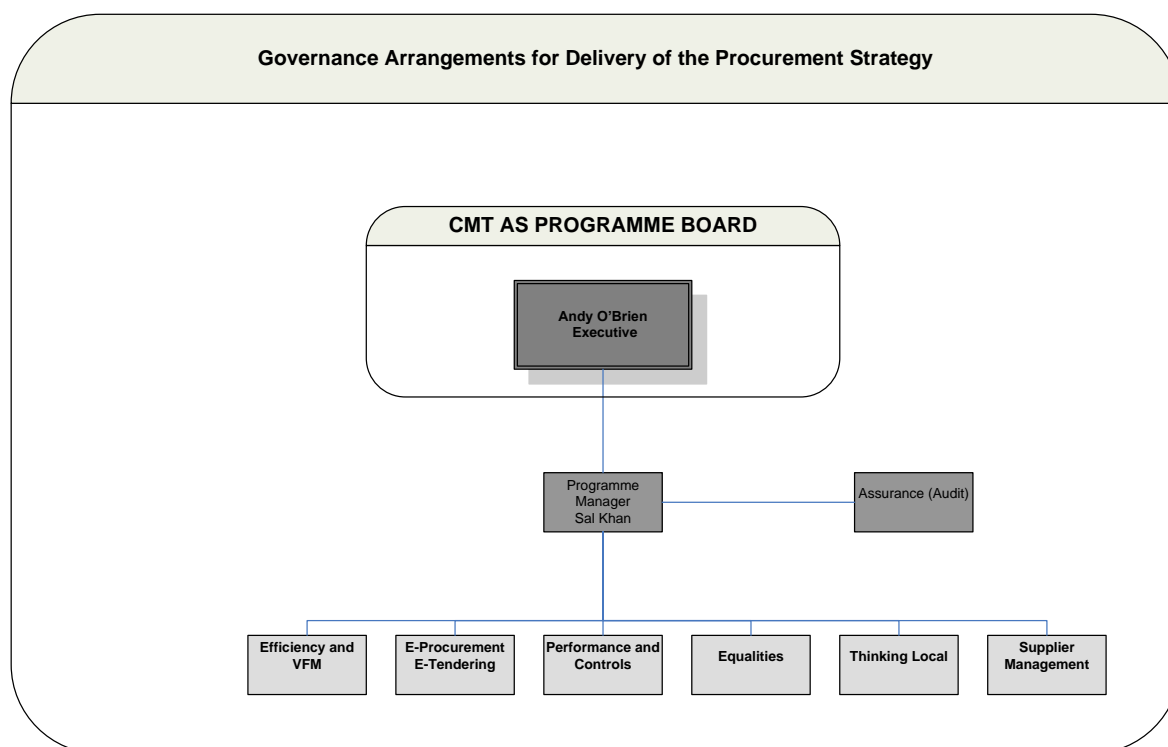

Section 7 - Key Outcomes and Benefits

Success will be measured by delivering benefits that ultimately improve service performance and quality through the goods and services that are procured by the Council. These include cashable and non-cashable efficiencies, cashable savings in procurements, better quality goods and services.

These will be measured and monitored through regular reporting up to the Corporate Management Team and the Corporate Programme Board and also through the Organisational Development and Customer Care Service Plan.

It is vital that this programme delivers tangible benefits. This is essential so that the Council is able to demonstrate the success of the strategy in helping improve service performance and quality, as well as delivering efficiencies and cost savings.

The Programme Board will have the key responsibility of identifying and monitoring benefits and ensuring their realisation via a balanced scorecard approach using the following four benefits categories:

- a) **Efficiencies** – cost savings and productivity / efficiency benefits are vital to the success of the strategy and to support the general budget position of the Council. The work carried out in the year 07/08 has started to identify and quantify an initial range of savings which will be built upon during the life-cycle of this Strategy.
- b) **Community Outcomes** – these benefits ensure that through this procurement strategy, local citizens, businesses and communities receive an improved quality of life through the procurement activities of the Council. The supplier base will include a wider range of local businesses which will in turn create more wealth for the community at large.
- c) **Improving Supplier Satisfaction** – these are benefits that ultimately lead to improved relationships with our supplier base and therefore improvements in the supply chain.
- d) **Organisational Development Enablers** – the strategy includes a range of components whose outcomes directly support and enable the realisation of the benefits defined in the above categories. Examples include building on existing best practice wherever it's available to reduce effort and timescales; staff training and development; communication strategies; strong programme and project management; human resource, ICT development and change management capacity.

These benefits will be clearly defined as the individual component project documentation is worked up.

Section 8 - Risk Analysis - Risk Register & Risk Matrix

A high-level risk analysis is presented below to provide a snapshot of perceived risks. As the strategy is developed, more detailed risk registers will be updated at project, programme and corporate level.

No	Risk	Target / Item Improvement Action to reduce risk	Manager	Review Date	Date of last approval	Revised Action Date	Strategy update			Risk Score
							Risk Cons	Likelihood	Score	
PS-01	Little or no support from Members	Ensure Strategy is supported by Leader and Deputy Leaders	SK	Pre Cabinet Approval	12-Nov-07	Subject to monthly review	Cat	Unlikely	10	Medium
PS-02	Little or no support from CMT	Ensure Strategy is approved by CMT and links into Corporate Plan	SK	Pre Cabinet Approval	12-Nov-07	Subject to monthly review	Cat	Unlikely	10	Medium
PS-03	Insufficient resources to deliver strategy	CMT endorses in principle approval of staff from respective services to work on the agenda	SK	Subject to monthly review	12-Nov-07		Maj	Poss	9	Medium
PS-04	Financial Management System overruns	Link into FMS Project Implementation	SK	Subject to monthly review	12-Nov-07		Cat	Unlikely	10	Medium
PS-05	Cash savings are not ring-fenced and redeployed to meet Council objectives	Ensure all savings are sustainable and are linked into Financial Services	SK	Subject to monthly review	12-Nov-07		Cat	Unlikely	12	High
PS-06	Central Government initiatives change focus for procurement	Keep abreast of current strategies	SK	Subject to monthly review	12-Nov-07		Maj	Unlikely	6	Medium
PS-07	Take up with suppliers not positive	Ensure effective dialogue and communication	SK	Subject to monthly review	12-Nov-07		Mod	Poss	5	Low
PS-08	FMS does not deliver required functionality	Ensure sufficient blue-printing in project workshops	SK	Subject to monthly review	12-Nov-07		Cat	Unlikely	12	High
PS-09	Lack of organisational change	Engage with Heads of Service regarding new environment	SK	Pre Cabinet Approval	12-Nov-07	Subject to monthly review	Cat	Unlikely	10	Medium

Strategic Risk Matrix					
Likelihood	Almost Certain	7	11	14	16
	Probable	4	8	12 <i>Lack of resources FMS functionality</i>	15
	Possible	2	5 <i>Lack of supplier take-up</i>	9 <i>Lack of resources</i>	13
	Unlikely	1	3	6 <i>Central Govt Focus</i>	10 <i>No support from CMT or Members FMS overrun Organisation change</i>
		Minor	Moderate	Major	Catastrophic
		Impact			